

By Bob Smith McCollum

Mastering the Fundamentals of Ozone:

Ozone Generation

A closer look at the second basic element of ozone

In the March 2008 issue of Water Quality Products, the IOA column discussed mastering the fundamentals of ozone and reviewed the four basic elements required to form fully functional ozone systems: oxygen/feed gas preparation, ozone generation, mass transfer and monitoring and control.

The series continues this month with a closer look at the second basic element: ozone generation.

Ozone Generation

Ozone (O_3) is created when diatomic oxygen (O_2) is exposed to an electrical field or ultraviolet (UV) light. Exposure to these high levels of energy causes a portion of the diatomic oxygen molecules to split into individual oxygen atoms. These free oxygen atoms combine with diatomic oxygen molecules to form ozone.

Ozone is an unstable molecule due to the weak bonds holding the third oxygen atom, making ozone a naturally powerful oxidizing and disinfecting agent. Ozone delivers oxidizing power either directly or through the generation of hydroxyl-free radicals in the decomposition of dissolved ozone into water.

This reaction yields three simultaneous processes: oxidation, disinfection and decomposition. During the oxidation process, ozone—directly and through the highly reactive hydroxyl-free radicals—can break chemical bonds of organic compounds. For example, the components of the cell walls of microorganisms can be oxidized and broken down by ozone. This process facilitates disinfection by disrupting and lysing cell walls, exposing the contents of the cell to further oxidation and inactivation.

Figure 1: Ozone formation

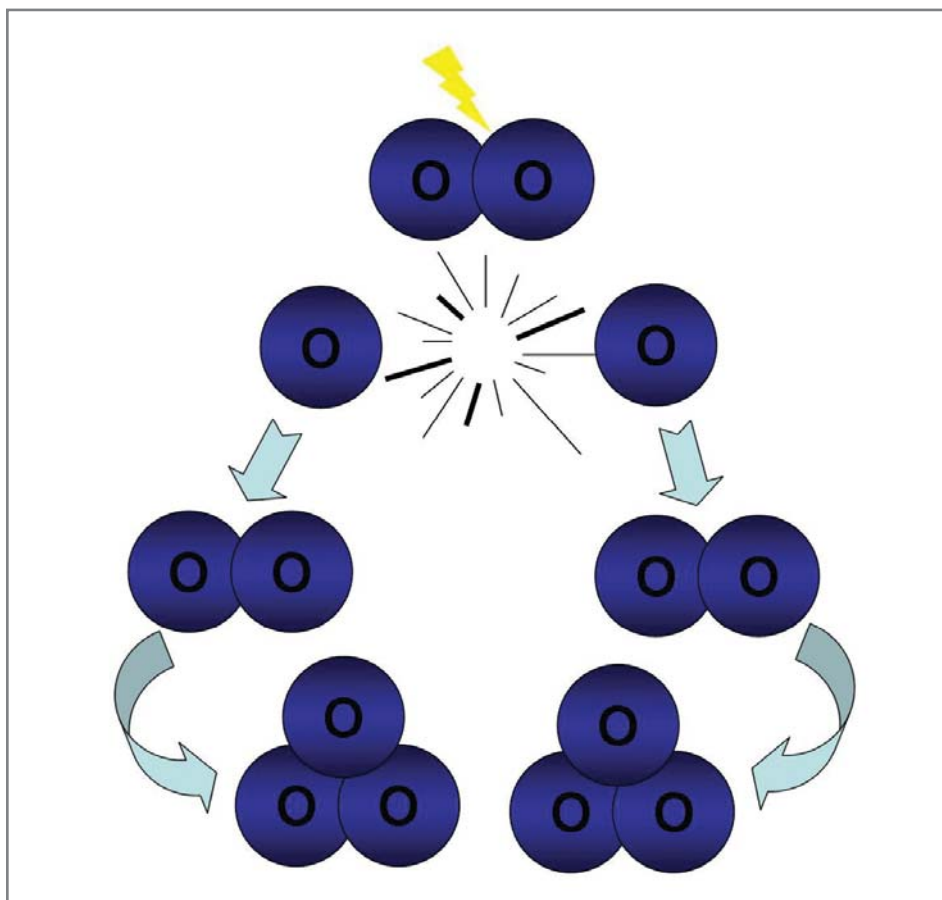

All common bacteria, viruses, molds, cysts and parasites can be destroyed by ozone in this manner. In the end, ozone decomposes to diatomic oxygen, leaving no unwanted residual taste or odor.

Ozone Generators

There are two principal technologies

used to generate ozone: UV and corona discharge for commercial and industrial applications.

UV ozone generators utilize UV light at 185-nanometer wavelength that shine on feed gas (air or concentrated oxygen) flowing through a suitable tube chamber. Fundamentally, UV generators

mimic the natural process responsible for the production of the ozone layer in the earth's outer atmosphere. In the stratosphere, high-energy UV radiation from the sun splits diatomic oxygen that results in ozone formation. Ozone generators based on UV radiation typically produce relatively small amounts of ozone at a very low concentration.

For most commercial-industrial processes, ozone is generated by corona discharge reactor cells. A corona discharge is a diffuse and continuous luminous electrical discharge that occurs when a high-voltage electric field is produced between conductive and dielectric surfaces.

A dielectric is a substance that is a poor conductor of electricity (i.e., an insulator) but an efficient supporter of an electric field. In a corona discharge ozone reactor cell, the dielectric facilitates the formation of a broad and continuous corona across its surface to maximize the effective area of the corona in the reactor cell. As shown in Figure 2, the dielectric material is bonded to one of the conductive electrode surfaces.

The space between the dielectric surface and the other conductive electrode surface forms an air gap called the dielectric gap. It is in this gap that the corona discharge forms when sufficient voltage is applied across the two electrodes. Corona discharge can produce moderate-to-high concentrations of ozone (typically 1 to 3% by weight from clean,

Figure 2: Corona discharge ozone reactor cell

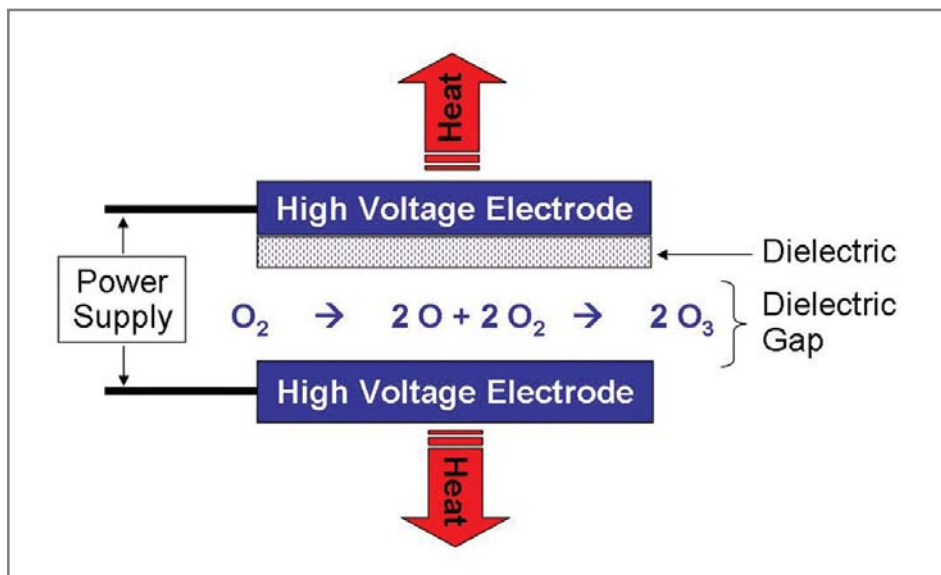

dry air and up to 15% weight from concentrated oxygen) over broad ranges of output.

The characteristics of the dielectric materials and the size of the dielectric gap largely determine the behavior of the reactor cell. The greater the effective dielectric gap, the greater the power that must be applied to form and sustain the corona.

Power is applied to a given reactor cell at a specific frequency. This frequency is typically optimized based on the characteristics of the reactor cell and is set by the manufacturer of the ozone generator. Ozone generators generally fall into three frequency classes: low frequency (50 to 60 Hz),

medium frequency (500 to 1,000 Hz) and high frequency (5,000 to 20,000+ Hz).

The ozone concentration and total ozone output from an ozone reactor cell or generator is a function of three user-controllable parameters: the power applied to the reactor cell, the oxygen concentration and the flow rate of the feed gas through the reactor cell. Ozone concentration and output (grams per hour or pounds per day) may be optimized by adjusting these parameters.

Ozone concentration and output from the reactor cell increase as more power is applied to the reactor cell. As with the frequency of the power,

the range of power that can be applied to the ozone reactor cell and the duration of each pulse is typically optimized and set by the manufacturer of the generator.

Corona discharge ozone reactors dissipate approximately 85% of the energy supplied to the cell as heat. Unfortunately, ozone becomes less stable at higher temperatures. As more power is applied, the reactor cell may increase in temperature, which can limit ozone production. All commercial corona discharge reactors incorporate some form of cooling to counteract this phenomenon.

Oxygen concentration and flow rate of the feed gas also impact the ozone output of the reactor. Generally, ozone concentration can be increased by increasing the oxygen concentration of the feed gas. As with any chemical reaction, increasing the concentration of a reactant increases the concentration of the product of the reaction. Reducing the feed gas flow rate through the generator also increases ozone concentration by increasing the amount of time the oxygen spends in the reactor.

The next article in this series will discuss mass transfer. *wqp*

Bob Smith-McCollum is vice president of marketing for Pacific Ozone. Smith-McCollum can be reached at 707.747.9600 or by e-mail at bsm@pacificozone.com.



OZONE. IT'S ELEMENTARY.



- O₂** Oxygen/Feed Gas Prep
- O₃** Ozone Generation
- MT** Mass Transfer
- CN** Control/Monitoring

Successful ozone systems require four basic elements: feed gas preparation, ozone generation, mass transfer, and control. As one of the oldest and most experienced firms in industrial ozone, Pacific Ozone optimizes these elements in complete, integrated ozone systems that meet the unique requirements of your process and application.

Ozone is elementary, *when you choose the right partner.*



**PACIFIC
OZONE™**

(707) 747-9600

www.pacificozone.com

Complete Integrated Solutions.

Single Trusted Source.